

LISTENING PART 1

Questions 1 – 7

For each question, choose the correct answer.

1 What did the girl buy on her shopping trip?

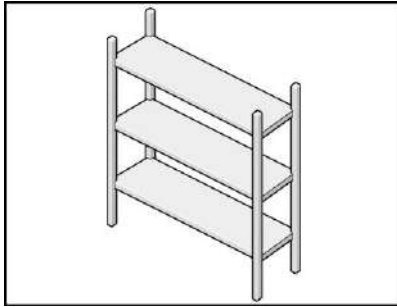

A

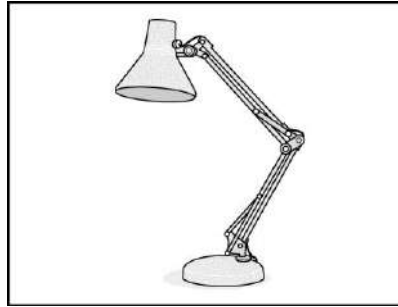

B

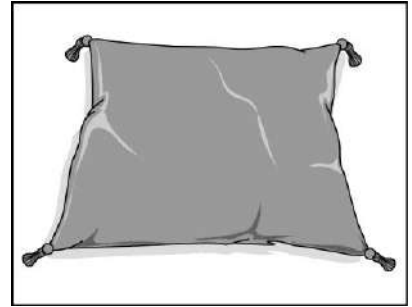

C

2 Why did the plane leave late?

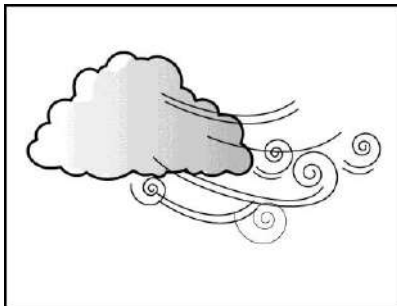

A

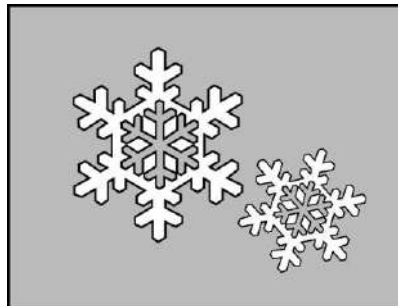

B

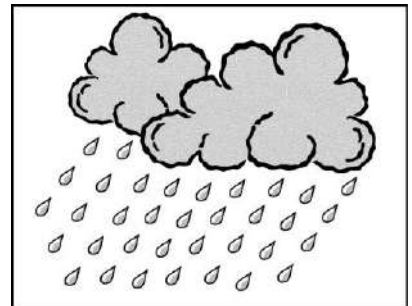

C

3 What activity does the woman want to book for the weekend?



A



B



C

4 Which cake will the girl order?

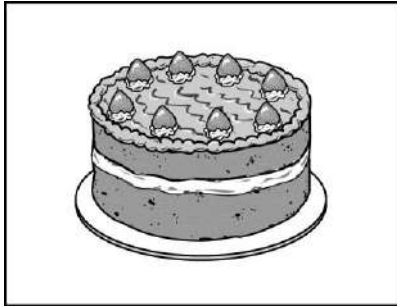

A

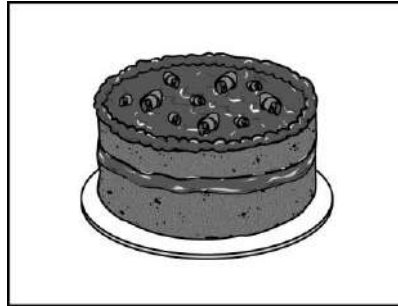

B

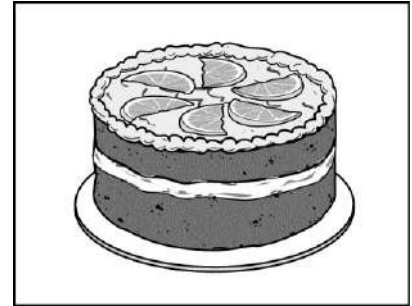

C

5 How much must customers spend to get a free gift?



A



B



C

6 What did the family do on Sunday?



A

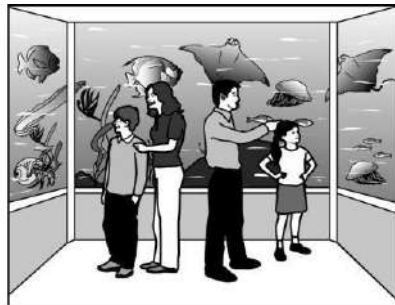

B

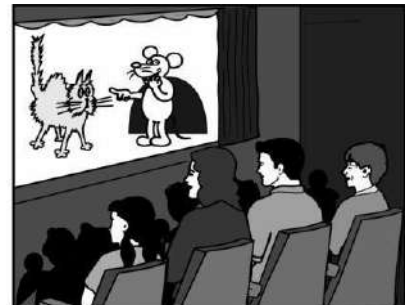

C

7 Which programme is on first?



A



B



C

LISTENING PART 2

Questions 8 – 11

For each question, choose the correct answer.

- 8** You will hear two friends talking about a new clothes shop
What does the girl say about it?
- A** The staff are helpful.
 - B** It only has the latest fashions.
 - C** Prices are reduced at the moment.
- 9** You will hear two friends talking about a pop band's website.
They think the site would be better if
- A** its information was up to date.
 - B** it was easier to buy concert tickets.
 - C** The band members answered messages.
- 10** You will hear a woman telling a friend about an art competition she's won.
How does she feel about it?
- A** upset that the prize isn't valuable
 - B** excited that the judges liked her picture
 - C** disappointed that she can't use the prize
- 11** You will hear two friends talking about the girl's flatmate.
The girl thinks that her flatmate
- A** is too untidy.
 - B** talks too much.
 - C** plays music too loud.

LISTENING PART 3

Questions 12 – 17

For each question, choose the correct answer.

You will hear an interview with a woman called Vicky Prince, a champion swimmer who now works as a swimming coach.

- 12** Vicky first went in for competitions because
- A** She had joined a swimming club.
 - B** Her parents were keen on swimming.
 - C** Her swimming teacher encouraged her.
- 13** As a teenager, Vicky's training involved
- A** exercising on land as well as in the water.
 - B** going without meals during the day.
 - C** traveling to a pool once a day.
- 14** What did Vicky find hard about her training programme?
- A** She couldn't go on school trips.
 - B** She lost some of her friends.
 - C** She missed lots of parties.
- 15** What helped Vicky to do well in the national finals?
- A** She was not expected to win.
 - B** She trained harder than usual.
 - C** She wanted to take a cup home.
- 16** As a swimming coach, Vicky thinks she's best at teaching people
- A** to deal with failure.
 - B** to improve their technique.
 - C** to get swimming qualifications.
- 17** Why has Vicky started doing long-distance swimming?
- A** She needed to get fit again.
 - B** She thought it would be fun.
 - C** She wanted to do some traveling.

READING PART 1

Questions 1 – 3

For each question, choose the correct answer.

1

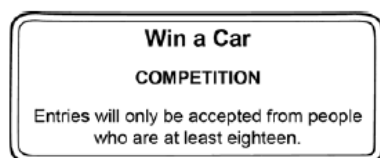

- A The competition is open to people over a certain age.
- B There is a maximum age limit for this competition.
- C Only eighteen-year-olds are allowed to enter this competition.

2



- Adam is telling Rachel to
- A post something for him.
 - B find out how to do something.
 - C give him something he needs.

3

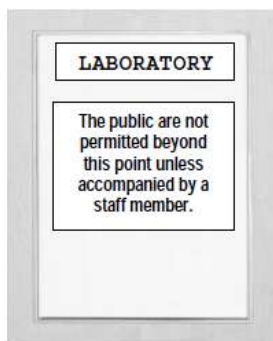

- A Members of staff must be accompanied if they wish to pass this point.
- B Members of the public can't go through unless they are visiting someone working here.
- C Members of the public may go further if a company employee goes with them.

READING PART 2

Questions 4-8

For each question, choose the correct answer.

The people below all want to visit a city market.

On the opposite page there are descriptions of eight markets. Decide which market would be the most suitable for the people below.



4. Jenny wants to buy locally-produced food traditional to the area. She needs somewhere convenient to eat, and as she's sightseeing in the city, the market shouldn't be far from local attractions.



5. Matt wants a market where he can get something to wear at reasonable prices, and something hot to eat. He's also keen on music, and likes finding rare recordings by different bands.



6. Sammie wants to visit a market after spending the day in the city. He would like to photograph a historic place, and buy a painting by someone unknown.



7. Alexia is looking for a really special necklace for her grandmother's birthday. She'd like to spend the whole day at the market, and wants to avoid the cold by staying inside.



8. Ella is looking for objects from other countries for her friends. She'd like to choose a second-hand book to read on the journey home, and wants a snack at the market, too.

City Markets

- A Beckfield Market**
This market's world-famous for second-hand camera equipment and books on photography. As well as an amazing range of cameras, we have old pictures of local places of interest for you to buy, and of course the stall owners are happy to give you advice for free! Don't miss our hot soup stall in cold weather.
- B Rosewell Hill**
Our market's in an amazing building that's hundreds of years old. Visitors find our late-night opening hours convenient, and there are always performers entertaining the crowds. We've recently opened more stalls specializing in pictures both from well-known artists and also those beginning their careers.
- C Camberwall Market**
There's lots to see in this interesting indoor market, so it's open from morning until late, in a fantastic modern setting. Find everything from rare gold and silver jewellery to designer clothes – although the prices aren't cheap, the quality's excellent. After shopping, enjoy a meal in a nearby restaurant.
- D Cobbledown Road**
A small market that's open in all weathers. Come and find something really fantastic – treat yourself or someone special! We have a wide selection of jewellery and musical instruments, produced locally by highly-skilled people, and home-made cakes to enjoy.
- E Oldford Lane**
Situated in the historic city centre, you'll find a wide range of jewellery and clothes. Arrive early to avoid disappointment – bargains are found in the morning, and the stalls pack up after lunch. If the weather's good, enjoy watching the world go by, although it gets very busy in the tourist season.
- F Purford Market**
Close to museums and art galleries, this is the place to buy something for lunch, as well as fresh fruit and special breads. Try the region's famous cheese – the producers are there with advice on different types. Eat on the seats situated around the market, watching the colourful scene and enjoying music from local bands.
- G Teddingley Market**
Situated under historic city walls, in this busy market you'll find a huge selection of great-value new and second-hand clothes. There are also stalls offering unusual albums by international singers, often hard to find in shops. Our world-food area allows you to taste food from abroad, cooked in front of you by international chefs.
- H Frome Place**
Stalls open during normal daytime shopping hours so, depending on the weather, there's plenty to entertain you the whole day. Try our sandwich bar if you're hungry, and look for an old copy of something by a favourite author. We also have gifts from all over the world.

READING PART 3

Questions 9 – 14

For each question, choose the correct answer.

THE COCONUT TREE

The coconut tree is thought to be one of the most valuable trees in the world. It is mostly found by the sea where there is a hot and wet (9)..... . The coconuts often fall into the sea and float on the water until they (10) another beach, where more trees then begin to grow.

Holiday makers often see the coconut tree as no more than an attractive sun umbrella that provides (11) However, this amazing tree has hundreds of (12) and more are still being discovered.

People have made houses, boats and baskets from the coconut tree's wood and leaves for centuries. Even today, if you take a (13) in your cupboards, you will find coconut oil products as (14)..... as medicine and desserts.

- 9 **A** temperature **B** condition **C** climate **D** weather
- 10 **A** reach **B** go **C** travel **D** arrive
- 11 **A** cloud **B** shade **C** dark **D** cold
- 12 **A** uses **B** jobs **C** roles **D** things
- 13 **A** scene **B** sight **C** look **D** view
- 14 **A** opposite **B** separate **C** strange **D** different

WRITING PART 1

Answer the question below. Write your answer in about 100 words.

Question 1

Read this email from your English-speaking friend Sandy and the notes you have made.

EMAIL

From: Sandy

Subject: Your visit!

Hi,

I'm so excited that you're coming to stay with me for a week!

On your first evening here, there's a rock concert in our town. Would you like to go to the concert or would you prefer us to relax at home?

Also, shall we go climbing in the mountains while you're here?

Let me know if you have any questions.

See you soon

Sandy

Me too!

No, because ...

Say which I prefer.

Ask Sandy ...

Write your **email** to Sandy using **all the notes**.

WRITING PART 2

Choose one of the questions below. Write your answer in about 100 words.

Question 2

You see this notice on an English-language website.

Articles wanted!

FILMS

What kind of films do you enjoy?

Do you prefer watching them at the cinema or at home? Why?

Write an article answering these questions and we will put it on our website!

Write your **article**.

Question 3

Your English teacher has asked you to write a story.

Your story must begin with this sentence.

As the plane flew lower, Lou saw the golden beaches of the island below.

Write your **story**.